

# PART-SVN26A-EN

## Installation

ALL phases of this installation must comply with NATIONAL, STATE AND LOCAL CODES

C800924P01

**RLY02807** Replaces RLY02257

**Time Delay Relay**

**WARNING: HAZARDOUS VOLTAGE-DISCONNECT POWER BEFORE SERVICING**

This document provides installation and checkout procedures for your RLY02807 Time Delay Relay.

### WARNING

This information is for use by individuals having adequate backgrounds of electrical and mechanical experience. Any attempt to repair a central air conditioning product may result in personal injury and/or property damage. The manufacturer or seller cannot be responsible for the interpretation of this information, nor can it assume any liability in connection with its use.

### APPLICATION

The RLY02807 Time Delay Relay is for use in compressor-run air conditioning and heat pump systems to delay the blower shut-off after the compressor has shut off. This delay allows the residual cooled air to be blown into the controlled space, increasing the efficiency of the system in cooling. Depending on electrical hookup in a heat pump system, delay of blower shut-off could also occur in heating.

Relay switching has 80 ( $\pm 16$ ) second delay timing.

The RLY02807 replaces RLY02257. Installation of the new ETDR is the same, terminals are labeled the same, but are in a different physical location on the new part (see figs 1, 2, 3, 4).

### ELECTRICAL RATINGS

#### CONTACT RATINGS:

Power Pole (Amperes per pole)—

	208/240/277 VAC
Full Load	7
Locked Rotor	36
Resistive	15
U.L. Approved Horsepower	3/4 hp

**Pilot Duty Pole** — Minimum: 3 VA at 24;  
Maximum: 25 VA at 24 VAC

**Minimum voltage required for pickup** — 75 percent of nominal coil voltage

**Input Voltage** — 24 VAC nominal

**Total Power Consumption** — relay deenergized — 0.5 VA  
relay energized — 4.0 VA

### INSTALLATION

#### WHEN INSTALLING THIS PRODUCT...

1. Read these instructions carefully. Failure to follow them could damage the product or cause a hazardous condition.
2. Check the ratings given in the instructions and on the product to make sure the product is suitable for your application.
3. Installer must be a trained, experienced service technician.
4. After installation is complete, check out product operation as provided in these instructions.

### WARNING: Hazardous Voltage!

Disconnect all electric power including remote disconnects before servicing. Follow proper lockout/ tagout procedures to ensure the power cannot be inadvertently energized. Failure to disconnect power before servicing could result in personal injury or death.

### LOCATION

Mount the relay on a flat, solid surface inside the equipment control box. The relay may be panel- or wall-mounted with the base vertical or horizontal. *If base is horizontal, it must be mounted with the terminals up.* Secure with the two screws through holes or slots in the mounting base or as shown in Fig. 1.

### WIRING

Disconnect power supply before connecting wiring to prevent electrical shock or equipment damage.

All wiring must comply with local codes and ordinances.

Crimp female quick-connects to the system wires, if needed, and attach to the male quick-connect terminals on the time delay board.

Terminal designations on RLY02257 corresponds directly to terminal designations on RLY02807 relay. Therefore, wires are to be connected to the same lettered or numbered terminal on the RLY02807 relay as they were on the RLY02257 relay. For example, the wire connected to terminal #4 on RLY02257 relay should be connected to terminal #4 on RLY02807 relay, etc. Terminals 1 (COM) and 3 (N.O.) are high voltage fan relay terminals.

### NO OFF DELAY WIRING

For NO OFF delay operation remove the red wire from terminal "A" and the green wire from terminal "T." Take the red wire that was removed from terminal "A" and connect to terminal "T." Next take the green wire that was removed from terminal "T" and connect to terminal "A." You may hear a double click when energized which is normal.

Make sure all wires are connected to the proper terminals on the time delay board for proper system operation. Refer to Figs. 1-4 for terminal designations and wiring connections.

Do not exceed contact and coil ratings when wiring into system.

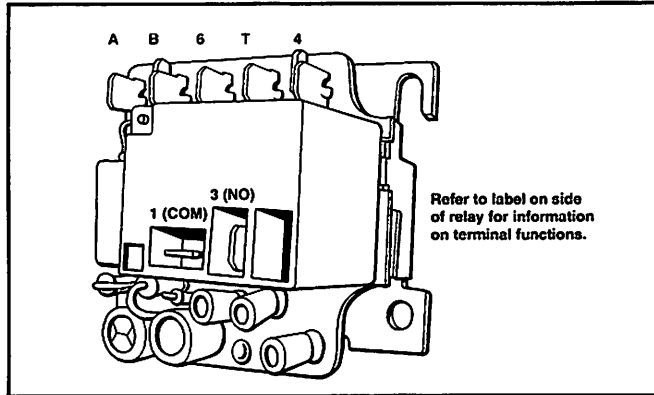

Figure 1. Mounting RLY02807 on panel

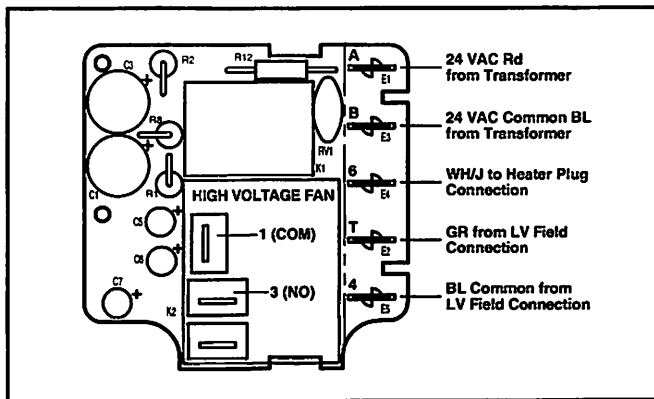

Figure 2. RLY02807 terminal designations

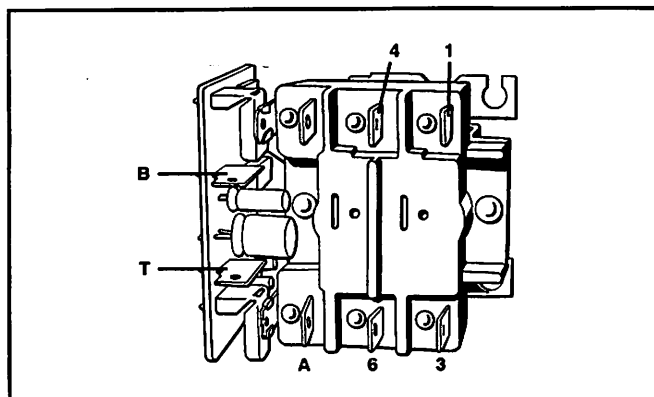

Figure 3. Mounting RLY02257 on panel

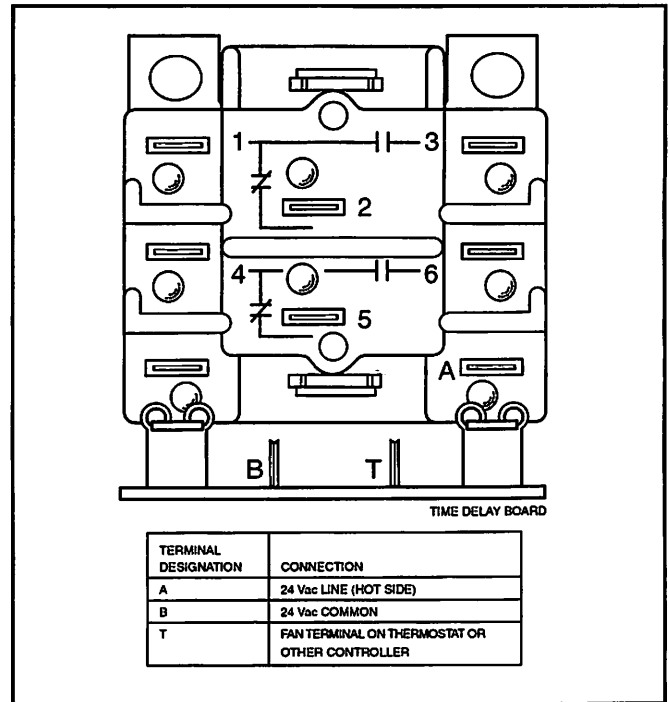

Figure 4. RLY02257 circuit and terminal designations

## OPERATION AND CHECKOUT

### OPERATION

When the thermostat calls for indoor blower operation, an electronic switch in the electronic board pulls in and powers the relay coil. When the call ends, the electronic switch in the electronic board holds in the relay coil for an additional 80 seconds. This increases the efficiency of the equipment and saves energy.

NOTE: When power is initially applied during installation or after power interruption, the relay will pull in for a maximum of 0.5 seconds and then drop out.

### CHECKOUT

When power is initially applied, check to make sure the relay pulls in for not more than 0.5 seconds and drops out. Then operate the relay and controlled equipment to make sure that the relay pulls in when the T terminal is energized with 24 VAC and that controlled equipment operates as intended. Relay pulls in after a short on delay of 2 seconds ( $\pm 0.7$ ). When the T terminal is deenergized (24 VAC removed), the indoor air blower should continue to operate until the delay period (80 seconds) ends.